

Pre-Owned



Falcon 900EX

S/N 108

2002





DASSAULT FALCON JET CORP.

200 Riser Road
Little Ferry, NJ 07643
USA

DASSAULT AVIATION

78, quai Marcel Dassault
Cedex 300
92552 Saint-Cloud Cedex
FRANCE

Falcon 900EX

S/N 108
SPECIFICATIONS



Falcon 900EX S/N 108 - 2002

ENGINE TYPE

Honeywell TFE731-60	on MSP Gold
#1 Engine s/n P112441	
#2 Engine s/n P112442	
#3 Engine s/n P112443	

APU TYPE

AlliedSignal GTCP36-150F	on MSP Gold
--------------------------	-------------

DATES

Manufactured - January 22, 2002
Entry into Service (EIS) - September 23, 2002

AVIONICS

ADS-B Out, CPDLC FANS-1/A, WAAS – LPV (Elite II – Baseline upgrade)

Flight Director	dual	Honeywell Primus 2000
Autopilot/Auto Throttle		Honeywell Primus 2000
Flight Management System (FMS)	triple	Honeywell FMZ-2000 (v6.1.1) - LPV
Global Positioning System (GPS)	dual	Honeywell GPS (WAAS capable)
Communication (VHF) Transceivers	dual	Collins VHF-422
Navigation (VHF) Receivers	dual	Collins VIR-432
Automatic Direction Finders	dual	Collins ADF-462
Distance Measuring Equipment	dual	Collins DME-442
ATC, Transponder	dual	Collins TDR-94D
Color Weather Radar		Honeywell Primus 880 with dual controllers
TCAS II		Collins (change 7.1)
Radar Altimeter	dual	Honeywell AA-300
High Frequency Communication	dual	Collins HF-9000
SATCOM		Honeywell MCS-7147
GoGo Biz		Avance L5 with Talk & Text
Head-Up Guidance System (HGS)		Flight Dynamics HGS-2850
Inertial Reference System	triple	Honeywell Laseref IV
Enhanced GPWS		AlliedSignal Mk V
Cockpit Voice Recorder		AlliedSignal CVR (2 hour)
Flight Data Recorder		AlliedSignal FDR (57 parameter)

MAINTENANCE

Inspections Due: 12 month - August 31, 2024; 1B @ 7726 hours; 1C/2C Inspection – September 30, 2025; Detailed Inspection Landing Gear – September 30, 2025; Landing Gear Overhaul – February 28, 2026.

PROGRAMS

Enrolled on Honeywell HAPP

Enrolled on Collins CASP

ADDITIONAL EQUIPMENT

Dual Davtron clocks

Triple Baker Flight Deck Audio

115 cubic foot oxygen bottle

Dual DVD players

15-inch and 18-inch LCD monitor

LCD side-ledge plug-in monitors

Coltech two (2) channel SELCAL

Wavejet microwave

Hi-Temp Oven

Teleflex "Tail" recognition lights

Securaplane camera: Belly forward & aft view, Tail mount forward view

EXTERIOR

White with Navy Blue lower fuselage, Red and Blue custom stripes (2016 – DFJ Wilmington).

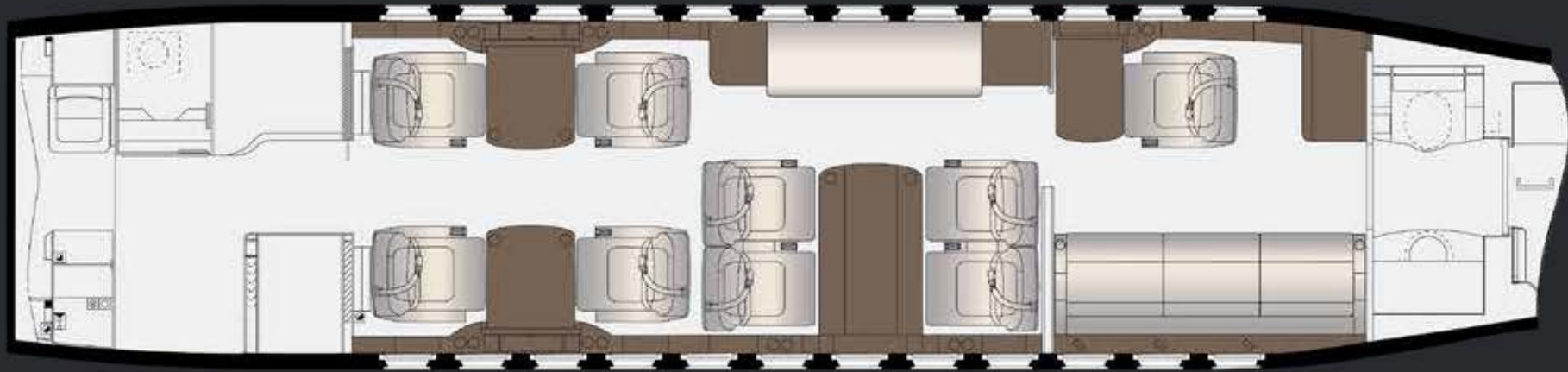

INTERIOR

Dogwood leather cabin seats with Pagoda leather piping, Focus Gold carpet, Lonwood Dakota Topseal Smooth (padded flooring) main entrance / galley area (August 2017). Medium Cherry stain Sycamore veneer. All Crewmember seats reupholstered August 2022.

SEATING

12 passengers: 4 forward club seats, 4-place dining group with opposing settee (not certified for TTOL), 3-place aft divan, aft cabin single executive chair, forward and aft lavatory, ERDA third crew seat.

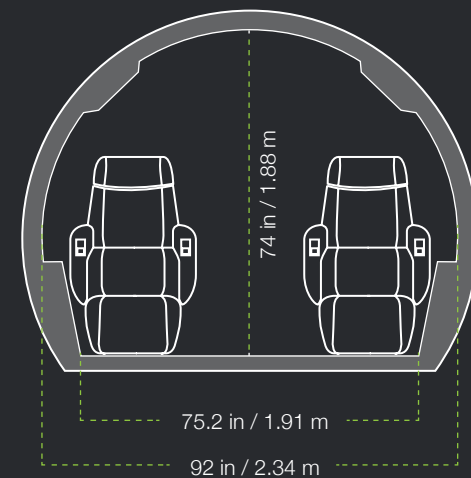

Falcon 900EX





















DASSAULT FALCON JET

Mark **VERDESCO**

Director, Pre-Owned Aircraft Sales
200 Riser Road
Little Ferry, NJ 07643
USA

Work Phone: + 1 201 541 4556

Fax: + 1 201 541 4620

E-mail: mark.verdesco@dassaultfalconjet.com

Andrew **STARK**

Regional Sales Manager, Pre-Owned Aircraft Sales
200 Riser Road
Little Ferry, NJ 07643
USA

Work Phone: + 1 201 541 4552

Fax: + 1 201 541 4620

Email: andrew.stark@dassaultfalconjet.com

DASSAULT AVIATION

Dominique **CRUCHON**

Director, Pre-Owned Aircraft Sales
78, quai Marcel Dassault
92552 Saint-Cloud Cedex 300
France

Work Phone: + 33 1 47 11 60 71

Fax: + 33 1 47 11 89 17

E-mail: dominique.cruchon@dassault-aviation.com

Yvon **DESIGNES**

Manager, Pre-Owned Aircraft Sales
78, quai Marcel Dassault
92552 Saint-Cloud Cedex 300
France

Work Phone: + 33 1 47 11 61 24

Fax: + 33 1 47 11 89 17

Email: yvon.desvignes@dassault-aviation.com

This aircraft is being brokered by the Dassault Falcon Jet Corp. Although it has made reasonable efforts to verify the accuracy of the information contained herein, all specifications and descriptions are being provided as introductory information and do not constitute representations or warranties. Verification remains the sole responsibility of the purchaser. Interested parties should rely on their own inspection of the aircraft, as well as conduct an independent pre-purchase evaluation at a qualified service center. Dassault Falcon Jet Corp. makes no representations as to the airworthiness of the aircraft. Aircraft is subject to prior sale and removal from the market.



