

Pre-Owned



Falcon 900DX

S/N 616

2007



 **DASSAULT
AVIATION**



DASSAULT AVIATION

78, quai Marcel Dassault
Cedex 300
92552 Saint-Cloud Cedex
FRANCE

DASSAULT FALCON JET CORP.

200 Riser Road
Little Ferry, NJ 07643
USA

Falcon 900DX

S/N 616

SPECIFICATIONS



Falcon 900DX S/N 616**ENGINE TYPE**

Honeywell TFE731-60	on MSP "GOLD"
---------------------	---------------

#1 Engine S/N P112728

#2 Engine S/N P112733

#3 Engine S/N P112731

APU TYPE

AlliedSignal GTCP36-150	S/N P534	under MSP
-------------------------	----------	-----------

MAINTENANCE

Under CAMP, "3C" inspection due in Nov 2025. Fresh CZI and MPI performed in Oct 2023.

EASY II OPTIONS

EASY II 4th Cert, LPV, ADS-B out, CPDLC ATN B1, CPDLC FANS 1A.

AVIONICS

FLIGHT CONTROLS		Honeywell EASy
FMS	Triple	Honeywell EASy FMS Function
COMM (VHF)	Triple	Honeywell TR-866B
ADF	Dual	Honeywell DF-855
ATC	Dual	Honeywell XS-857-A
DME	Dual	Honeywell DM-855
XPNDR	Dual	Honeywell XS-857A w/ Mode S
GPS	Dual	Honeywell
SATCOM		Aircell Axxess II level D (2 cordless handsets)
HFCOM	Dual	Collins HF9000
WEATHER RADAR		Honeywell Primus 880
RADIO ALTIMETER	Dual	Honeywell RT-300
EGPWS		Honeywell L with Windshear
TCASS		ACSS TCAS 3000
MICRO INERTIAL REF UNIT (MIRU)	Triple	Honeywell Laseref V
SSCVR		Honeywell 120 mn
SSFDR		Honeywell
AIRSHOW		Airshow 410

AVIONICS

ELT

ELTA ADT-406

ADDITIONAL EQUIPMENT

Triple Honeywell AV-900 Flight Deck Audio,

Flight Deck Printer, Electronic Jeppesen Charts,

Honeywell Data Acquisition Unit,

Lightning Sensors,

Audio-International Multistandard dual DVD,

2 ea. 20" LCDs, 8 ea. 8.4" Rosen LCD's (8 receptacles),

2 ea. Aux Audio Interface (MP3, I Pod), CD player,

115 VAC / 60 Hz,

Essenza Coffee machine, TIA high Temp Oven,

TIA microwave,

Goodrich Ice Detectors,

Teleflex Reco. Lights,

3 ea. Securaplane Video Cameras (2 Belly, 1 Fin),

Enlarged Oxygen bottle (115 cu.ft.),

2 ea. 12-Man Life Rafts with 406 MHz ELT.

EXTERIOR

White with red waved stripes (Original).

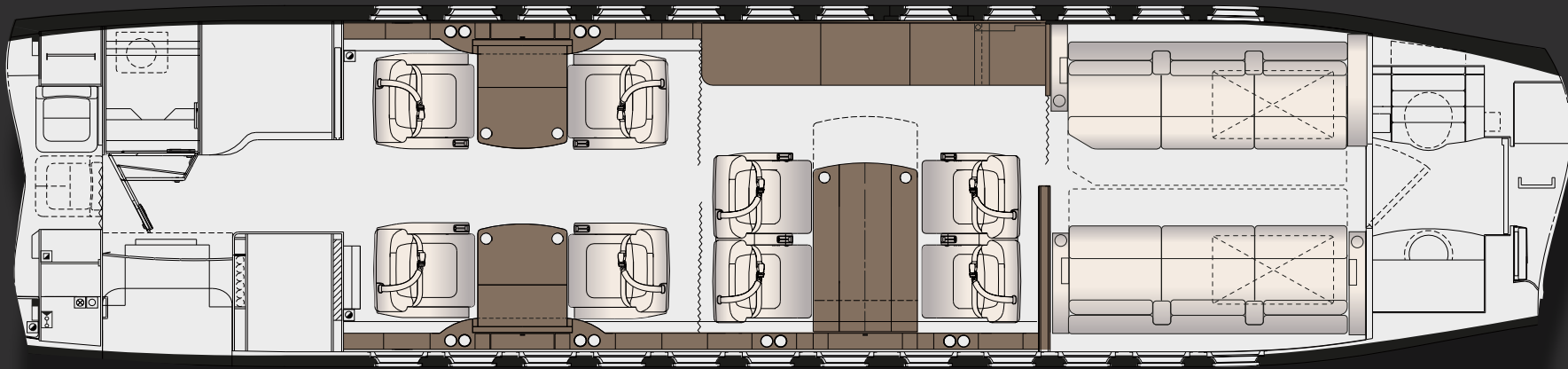

INTERIOR

Rounded Look. Tan leather seats, Tan fabric sofas, with Creme custom designed carpet, Elm Burl wood veneer, «Chablis» headliner, 24K Gold polished metal plating. Partially refurbished by TAG in 2020.

SEATING

14 Pax floorplan w/ 3rd crew seat. FWD & AFT lavatories, Galley pocket door, Mid-cabin tracking curtain, Aft cabin divider w/ stowable curtain
2 Divans w/10" Extension (Electrically Ctrl'd)

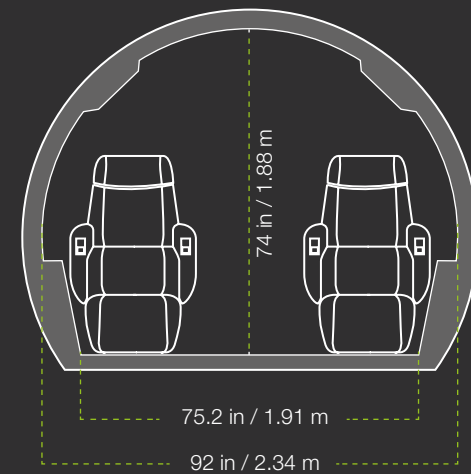

Falcon 900DX

S/N 616

PHOTO GALLERY



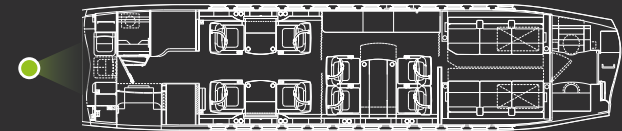

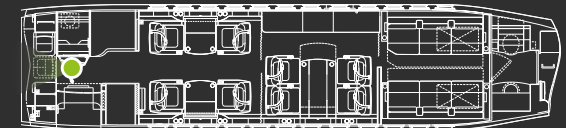

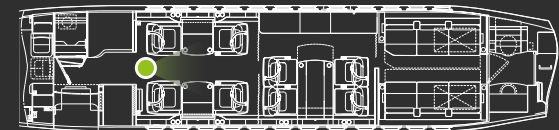

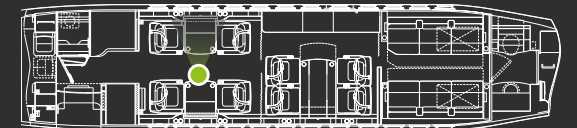

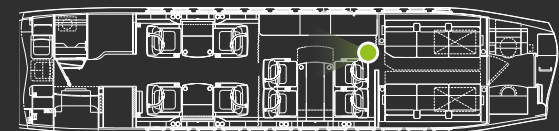



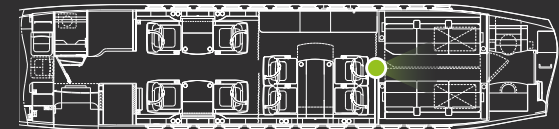

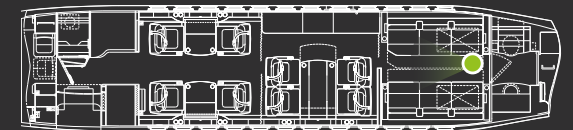

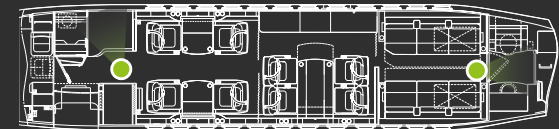
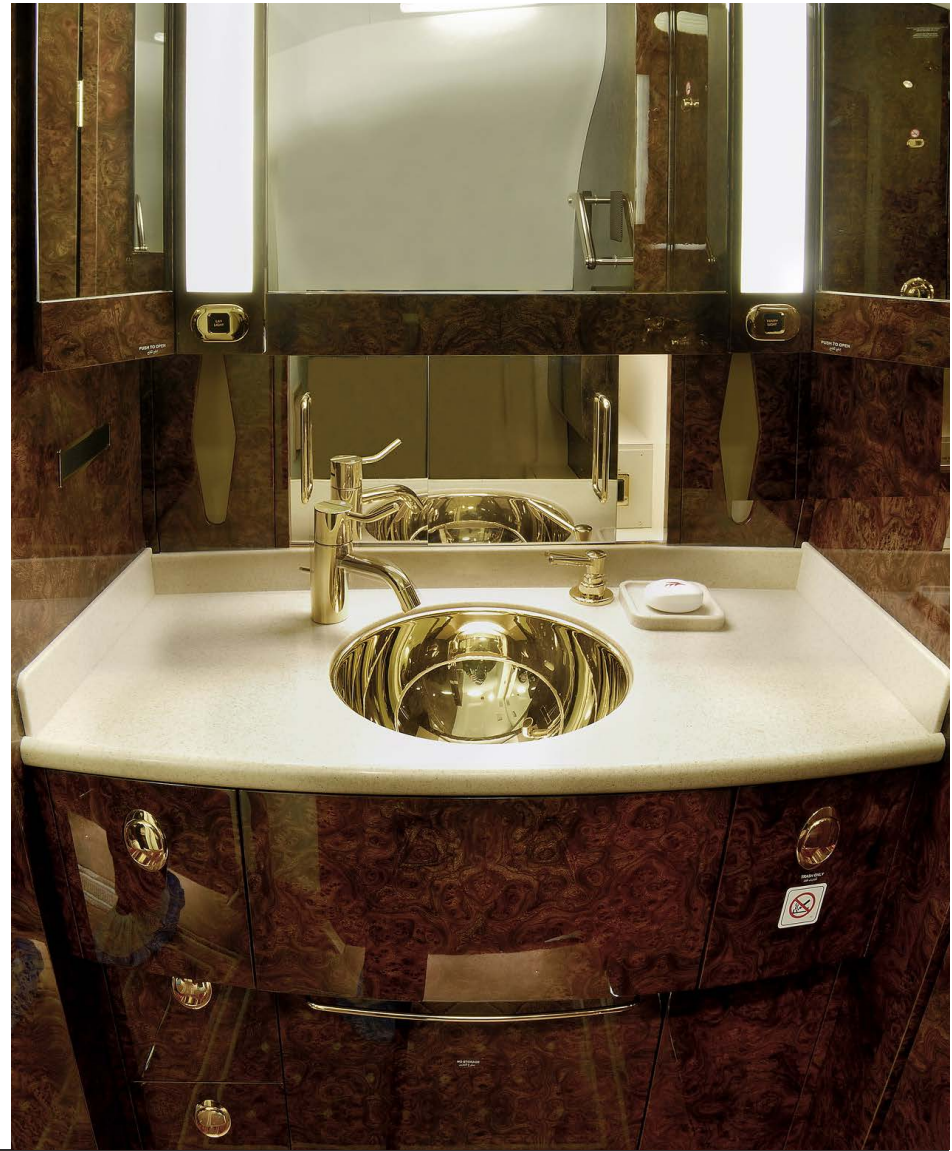

DASSAULT AVIATION

Dominique **CRUCHON**

Director, Pre-Owned Aircraft Sales

78, quai Marcel Dassault

92552 Saint-Cloud Cedex 300

France

Work Phone: + 33 1 47 11 60 71

Fax: + 33 1 47 11 89 17

E-mail: dominique.cruchon@dassault-aviation.com

Yvon **DESIGNES**

Manager, Pre-Owned Aircraft Sales

78, quai Marcel Dassault

92552 Saint-Cloud Cedex 300

France

Work Phone: + 33 1 47 11 61 24

Fax: + 33 1 47 11 89 17

Email: yvon.desvignes@dassault-aviation.com

DASSAULT FALCON JET

Mark **VERDESCO**

Director, Pre-Owned Aircraft Sales

200 Riser Road

Little Ferry, NJ 07643

USA

Work Phone: + 1 201 541 4556

Fax: + 1 201 541 4620

E-mail: mark.verdesco@falconjet.com

Andrew **STARK**

Regional Sales Manager, Pre-Owned Aircraft Sales

200 Riser Road

Little Ferry, NJ 07643

USA

Work Phone: + 1 201 541 4552

Fax: + 1 201 541 4620

Email: andrew.stark@falconjet.com



