

Pre-Owned



Falcon 900EX^{EASy}

S/N 205
2008





DASSAULT AVIATION

78, quai Marcel Dassault
Cedex 300
92552 Saint-Cloud Cedex
FRANCE

DASSAULT FALCON JET CORP.

200 Riser Road
Little Ferry, NJ 07643
USA

Falcon 900EX^{EASy}

S/N 205

SPECIFICATIONS



Falcon 900EX^{EASY} S/N 205 - 2008

ENGINE TYPE

Honeywell TFE731-60-1C	on MSP "GOLD"
#1 Engine: S/N P112805	
#2 Engine: S/N P112806	
#3 Engine: S/N P112808	

APU TYPE

Honeywell GTCP36-150(F)	S/N P558	on MSP "GOLD"
-------------------------	----------	---------------

MAINTENANCE

On CAMP. Next "C-Check" inspection (1C & 3C) due August 2026. Avionics under MSP.

EASY II OPTIONS

EASY II 4th Cert., SBAS-LPV, ADSB-OUT, CPDLC ATN-B1, FANS 1/A+

AVIONICS

Honeywell Primus Epic System (EASy II 4th Cert)

VHF COMMUNICATION SYSTEMS	Triple	Honeywell TR-866B
HF COMMUNICATION SYSTEMS	Dual	Rockwell Collins HF-9000 w/ SELCAL
FLIGHT DECK AUDIO	Triple	Honeywell AV-900
EMERGENCY LOCATOR TRANSMITTER		Elta ADT-406 (Tri-Band) w/ NAV Interface
TELECOMMUNICATION SYSTEM		Aircell Axxess II
SATCOM SYSTEM		Honeywell Jetwave KA-BAND (Wifi)
VOR/ILS/MARKER NAVIGATION SYSTEM	Dual	Honeywell NV-875A
ADF SYSTEMS	Dual	Honeywell DF-855
GLOBAL POSITIONING SYSTEM	Dual	Honeywell (SBAS capable)
FLIGHT MANAGEMENT SYSTEM	Triple	Honeywell EASy
ELECTRONIC JEPPESEN CHARTS		Honeywell EASy
COLOR WEATHER RADAR SYSTEM		Honeywell Primus 880
DME SYSTEMS	Dual	Honeywell DM-855
ATC, TRANSPONDER	Dual	Honeywell XS-857A Mode S
RADIO ALTIMETER SYSTEM	Dual	Honeywell RT-300
TCAS II SYSTEM		Acss TCAS-3000 (TCAS 7.1)
MODULAR AVIONICS UNIT	Dual	Honeywell EASy MAU-920
HEAD-UP GUIDANCE SYSTEM		Rockwell Collins HGS-4860

AVIONICS

MICRO INERTIAL REFERENCE SYSTEM	Triple	Honeywell Laseref V
COCKPIT VOICE RECORDER		Honeywell SSCVR (2 Hrs)
FLIGHT DATA RECORDER		Honeywell SSFDR (Provisions for 88 parameters)
EGPWS W/ WINDSHEAR		Honeywell EASy

ADDITIONAL EQUIPMENT**Honeywell EASy:**

Communications Management Function (CMF),
Miltope TP-4840 Flight Deck Printer.

Rockwell Collins FC HD:

Venue Entertainment System with 3D Interactive MAP,
1ea. 10.6" Touch Screen Control monitor, Dual Blue Ray player,
2ea. (17.5" & 19") HD Bulkhead monitors,
6ea. Ingenio Cabin tablet arms and holders,
10ea. Ingenio Cabin receptacles w/ USB chargers,
2ea. HDMI Aux Panels and AVOD Stage System.

Galley:

Central Water System,
Hot Cup, Krups Nespresso Coffee machine,
Xtra wide high temp Oven,
Microwave Oven.

Misc:

API Winglet STC (2015 Certification),
Cabin Clean Air Ionization System,
Main Batteries charging w/ GPU,
Meggitt MK2 Secondary Flight Display,
115Cu.Ft. Enlarged O² bottle,
230 VAC/50hz/2000VA Inverter w/12 outlets,
3rd Eros Oxygen Full Face Mask,
EMTEQ LED direct/indirect lighting,
Telescopic tow bar,
2 ea. 12 man life rafts.

EXTERIOR

Brand new livery performed in march 2025 by Duncan

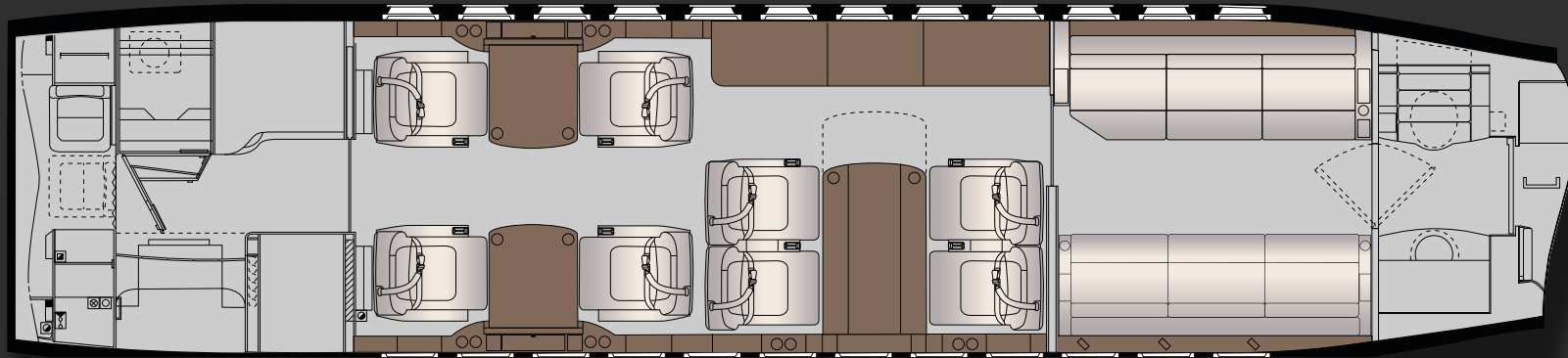

INTERIOR

Cabin Refurbishment performed in 2021: mat finish dark wood veneer, satin nickel metal plating.

SEATING

14 Pax floor plan w/ 3rd crew seat.

FWD & AFT lavatories, Galley pocket door,

AFT solid partition w/electric Roller Curtain,

2 Divans (10" Berth Electrical Controlled)

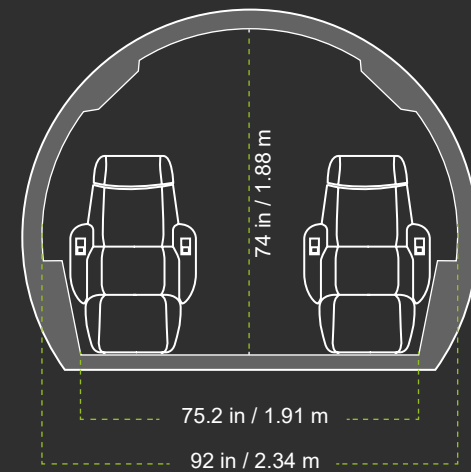

Falcon 900EX^{EASy}

S/N 205

PHOTO GALLERY



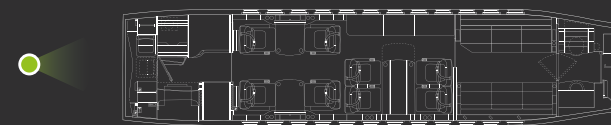

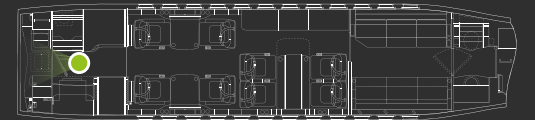

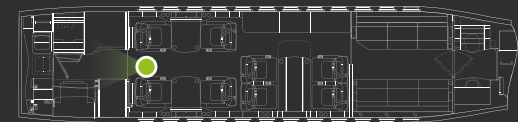

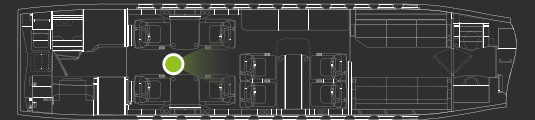

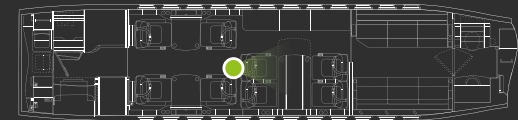



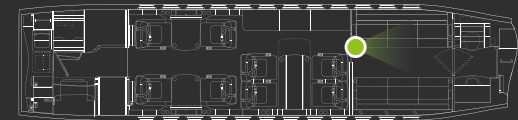

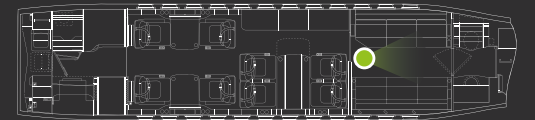

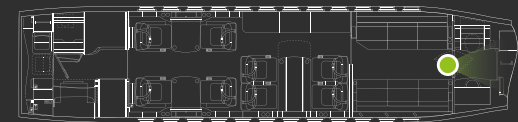

DASSAULT AVIATION**Yvon DESVIGNES**

Director, Pre-Owned Aircraft Sales
78, quai Marcel Dassault
92552 Saint-Cloud Cedex 300
France
Work Phone: + 33 1 47 11 61 24
Mobile: + 33 6 08 16 19 73
E-mail: yvon.desvignes@dassault-aviation.com

Nicolas MARTIN

Manager, Pre-Owned Aircraft Sales
78, quai Marcel Dassault
92552 Saint-Cloud Cedex 300
France
Work Phone: + 33 1 47 11 51 02
Mobile: + 33 6 26 79 50 50
Email: Nicolas.Martin@dassault-aviation.com

DASSAULT FALCON JET**Mark VERDESCO**

Director, Pre-Owned Aircraft Sales
200 Riser Road
Little Ferry, NJ 07643
USA
Work Phone: + 1 201 541 4556
Fax: + 1 201 541 4620
E-mail: Mark.Verdesco@dassaultfalconjet.com

