

Pre-Owned



Falcon 2000LX

S/N 152
2008



 **DASSAULT
AVIATION**



DASSAULT AVIATION

78, quai Marcel Dassault
Cedex 300
92552 Saint-Cloud Cedex
FRANCE

DASSAULT FALCON JET CORP.

200 Riser Road
Little Ferry, NJ 07643
USA

Falcon 2000LX

S/N 152

SPECIFICATIONS



Falcon2000LX S/N 152 - 2008**ENGINE TYPE**

PW 308C		on ESP GOLD
#1 Engine: PCE-CF0335	5 612 hours - 2 723 cycles	
#2 Engine: PCE-CF0336	6 383 hours - 3 042 cycles	

APU TYPE

Honeywell GTCP36-150 (F2M)	S/N P499	on MSP GOLD
----------------------------	----------	-------------

MAINTENANCE

Under CAMP. Avionics on HAPP. "3C check" due in October 2026 (Latest February 2027)

EASy OPTIONS

EASy II 4th Cert: Baseline, SBAS-LPV, ADS-B OUT, CPDLC ATN-B1, FANS-1A+

AVIONICS

Honeywell Primus Epic System (EASy II, 4th Cert)		
VHF COMMUNICATION SYSTEMS	Dual	Honeywell TR-866B
HF COM	Dual	Collins HF 9000 W/ SELCAL
FLIGHT DECK AUDIO	Triple	Honeywell AV-900
EMERGENCY LOCATOR TRANSMITTER		Elta ADT-406 w/ NAV Interface
SATCOM SYSTEM		Iridium Aircell Axess II
COMMUNICATION MANAGT FUNCTION		EASy/AFIS
VOR/ILS/MARKER NAVIGATION SYSTEM	Dual	Honeywell NV-875A
ADF SYSTEM	Dual	Honeywell DF 855
GPS	Dual	Honeywell
FLIGHT MANAGEMENT SYSTEM	Dual	Honeywell Primus EPIC
COLOR WEATHER RADAR SYSTEM		Honeywell Primus 880
DME SYSTEM	Dual	Honeywell DM-855
AIR TRAFFIC CONTROLLER	Dual	Honeywell XS-857A (Mode S)
RADAR ALTIMETER SYSTEM		Honeywell RT-300
TCAS II SYSTEM		ACSS TCAS-3000 (Change 7.1)
MODULAR AVIONICS UNIT	Dual	Honeywell MAU-920
MICRO INERTIAL REFERENCE SYSTEM	Dual	Honeywell Laseref V
COCKPIT VOICE RECORDER		Honeywell SSCVR (120 Minutes)

AVIONICS

FLIGHT DATA RECORDER	Honeywell SSFDR
EGPWS	Honeywell EASy

ADDITIONAL EQUIPMENT**Entertainment:**

Airshow 410
 Audio International AV-9693 cabin entertainment system
 Dual DVD player
 2ea. 20" Bulkhead LCD monitor

Galley:

Central Water System
 Iacobucci Espresso coffee maker
 TIA High-Temp oven

Misc:

115VAC 60HZ 2000VA Inverter w/6 outlets
 Main Batteries Charging w/ GPU
 Lightning Sensor LSS-860
 Goodrich Ice Detector
 Fight Deck Video Interface
 Securaplane Video Camera System w/ Glareshield Camera

Lights:

2ea. vertical fin Teleflex recognition light
 EMTEQ LED direct/indirect lighting

Emergency:

2ea. 8-man Life Rafts
 115Cu Ft enlarged O² bottle

SB:

Increased MTOW
 Brake / Wheel Well Heat

EXTERIOR

Overall white body, with dark blue straight stripes on Fuselage. New Paint in 2021.

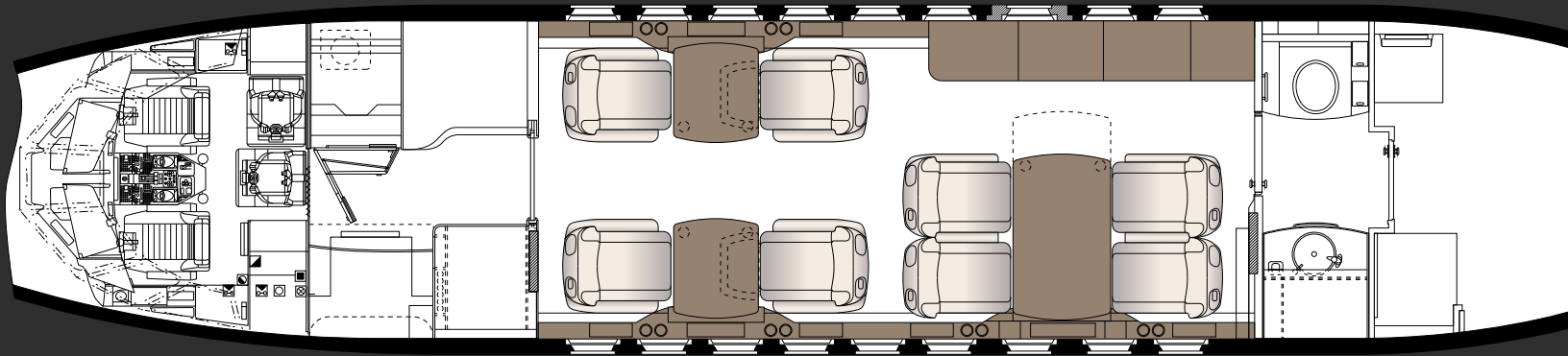

INTERIOR

Refurbished in 2016. Light beige leather seats, all-over-the-pattern dark blue Carpet (installed in 2021), Hi-Gloss Marbled Etimoe wood veneer and Satin Champagne Gold metal plating.

SEATING

8 Pax Floorplan w/3rd crew seat.

Galley Pocket Door, Aft and Fwd Lavatories.

Mid Cabin with Dining Group, and Credenza.

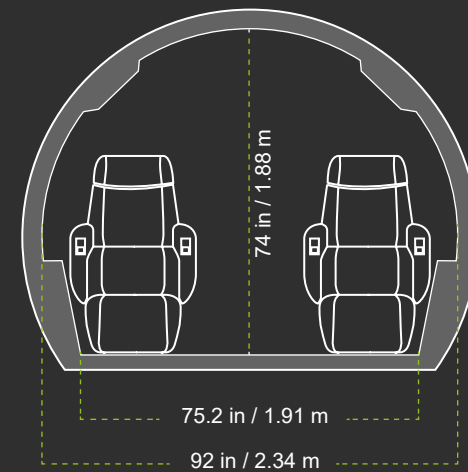

Falcon 2000LX

S/N 152

PHOTO GALLERY



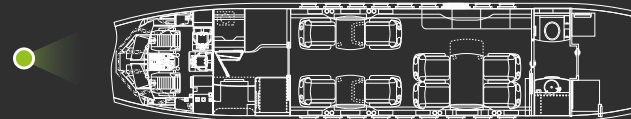

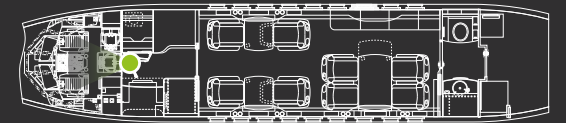

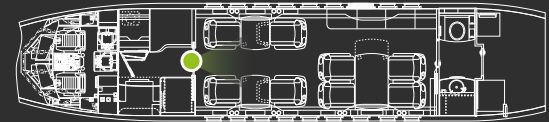

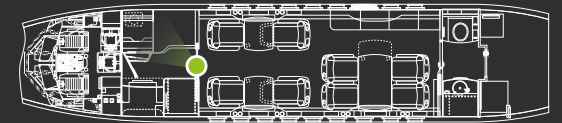

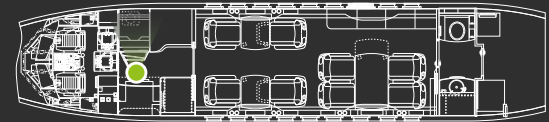

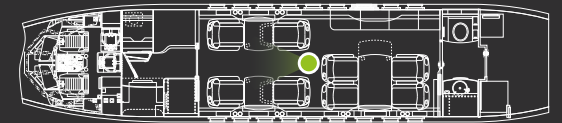



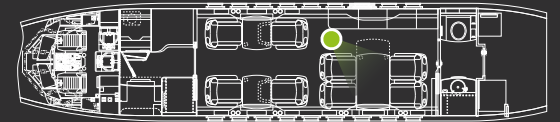

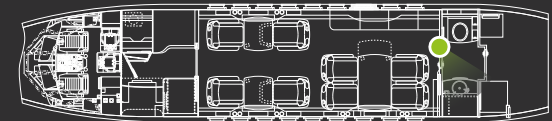

DASSAULT AVIATION**Yvon DESVIGNES**

Director, Pre-Owned Aircraft Sales

78, quai Marcel Dassault

92552 Saint-Cloud Cedex 300

France

Work Phone: + 33 1 47 11 61 24

Mobile: + 33 6 08 16 19 73

E-mail: yvon.desvignes@dassault-aviation.com

Nicolas MARTIN

Manager, Pre-Owned Aircraft Sales

78, quai Marcel Dassault

92552 Saint-Cloud Cedex 300

France

Work Phone: + 33 1 47 11 51 02

Mobile: + 33 6 26 79 50 50

Email: Nicolas.Martin@dassault-aviation.com

DASSAULT FALCON JET**Mark VERDESCO**

Director, Pre-Owned Aircraft Sales

200 Riser Road

Little Ferry, NJ 07643

USA

Work Phone: + 1 201 541 4556

Fax: + 1 201 541 4620

E-mail: Mark.Verdesco@dassaultfalconjet.com

