

Pre-Owned



Falcon 900EX

S/N 118

2003



 **DASSAULT
AVIATION**



DASSAULT AVIATION

78, quai Marcel Dassault
Cedex 300
92552 Saint-Cloud Cedex
FRANCE

DASSAULT FALCON JET CORP.

200 Riser Road
Little Ferry, NJ 07643
USA

Falcon 900EX

S/N 118

SPECIFICATIONS



Falcon 900EX S/N 118**ENGINE TYPE**

Honeywell TFE 731-60-1C	on MSP "GOLD"
#1 Engine S/N P112471	
#2 Engine S/N P112472	
#3 Engine S/N P112473	

APU TYPE

AlliedSignal GTCP36-150(F)	S/N P438	on MSP "GOLD"
----------------------------	----------	---------------

MAINTENANCE

Under CAMP. Next "C check" due September 2026 («LDG Overhaul» in December 2026)

PRIMUS 2000 OPTIONS

Primus 2000 EFIS Avionics with CPDLC & ADS-B Out, FMS 6.1, LPV, TCAS 7.1

AVIONICS

AP		Honeywell Primus 2000
FMS	Triple	Honeywell FMZ 2000 with Dual GPS
COMM (VHF)	Triple	Collins VHF-422C
NAV (VHF)	Dual	Collins VIR-432
ADF	Dual	Collins ADF-462
DME	Dual	Collins DME-442
FLIGHT DECK AUDIO	Triple	Baker with 3 Telex Airman 750 Headsets
XPNDR	Dual	Collins TDR-94D Mode S
SELCAL	Dual	Coltech Selcal CSD- 714
SATCOM		Iridium Aircell AXXESS II
HF COM	Dual	HF-9000
AFIS		Honeywell VHF & SATAFIS with Sky Printer
WEATHER RADAR		Honeywell Primus 880 w/ Dual Controllers
RADIO ALTIMETER	Dual	Honeywell AA-300
EGPWS		Honeywell MARKV (-212-212)
TCASS		Collins TCAS 4000
HEAD-UP GUIDANCE SYSTEM		Flight Dynamics HGS-2860

AVIONICS

LRNAV	Triple	Honeywell Laseref IV
CVR		Honeywell SSCVR 120 mn
FDR		Honeywell SSFDR with QAR
ELT		SOCATA ELT96 (JAA Compliant)

ADDITIONAL EQUIPMENT**Entertainment:**

Airshow 400 w/ Audio International AV 9690W subwoofer,
 Dual Audio International multi regional DVD/CD players,
 1ea. 15" & 1ea. 18" Rosen LCD monitors,
 8ea. plug in receptacle and 2 ea. 5.6" Rosen plug in LCD's.

Galley-Aux Galley:

Central Water System,
 TIA microwave oven,
 TIA High Temp Oven,
 TIA warmer Oven,
 Iacobucci Espresso machine.

Misc:

Enlarged oxygen bottle (115 CuFt),
 B.F. Goodrich Ice Detector,
 2ea. Teleflex vertical fin Reco Lights,
 Dual navigation wing tip position lights 230VAC/50 Hz/ 1200 VA static inverter,
 Battery Temperature Monitoring System Security System.

SB Applied:

Brake/Wheel Well Heat,
 Increase MTOW.

EXTERIOR

White fuselage with blue belly and top fin, and gold and blue stripes on fuselage and vertical fin.

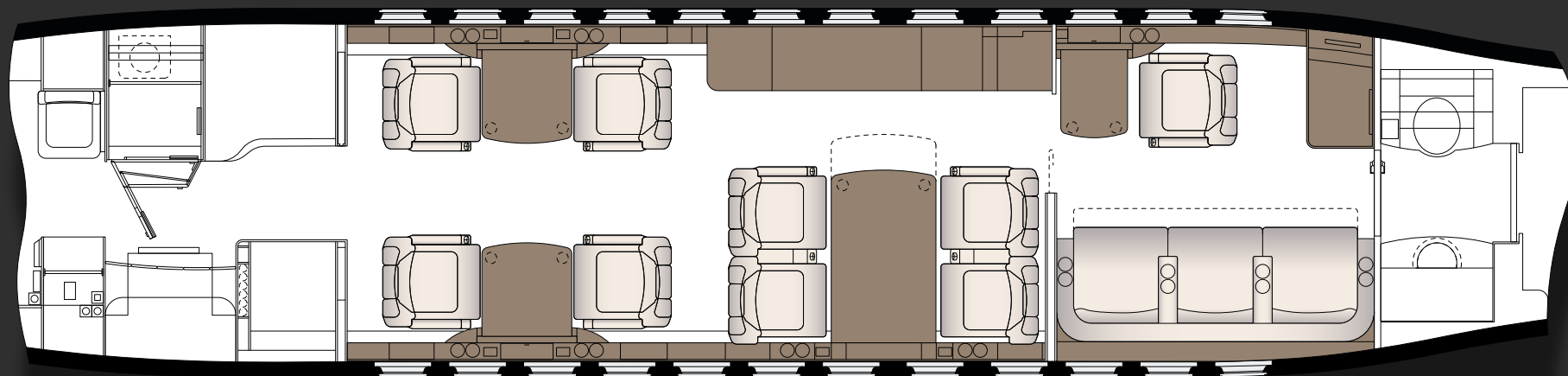

INTERIOR

Almond-Beige cabin harmony, leather on seats & sofa,
European Beech wood veneer, Polished Champagne metal plating.

SEATING

12 Pax floor plan w/ 3rd crew seat.
Galley sliding pocket door, FWD and Aft Lavatories
AFT cabin divider w/stowable curtain, AFT cabin w/1 Sofa and executive Seat

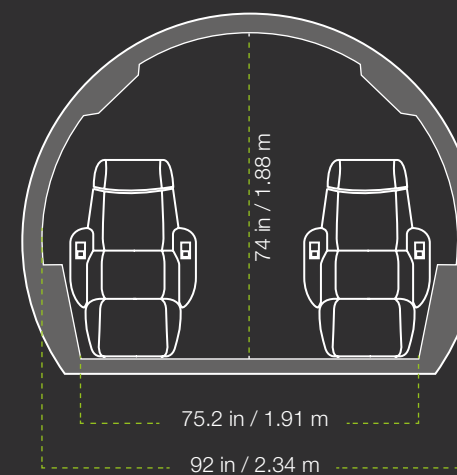

Falcon 900EX

S/N 118

PHOTO GALLERY



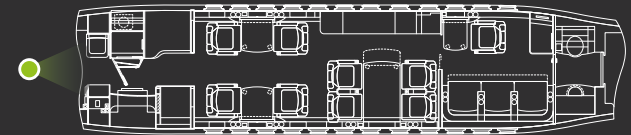

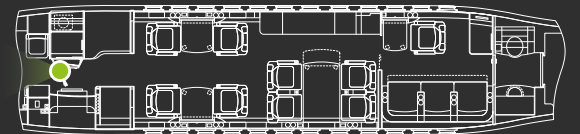

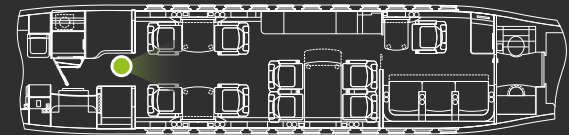

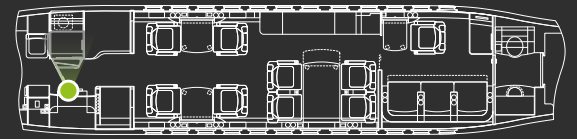

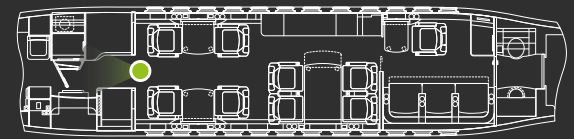

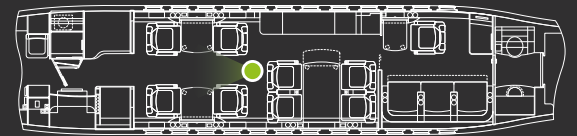

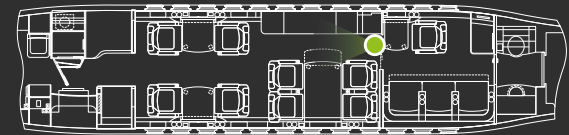

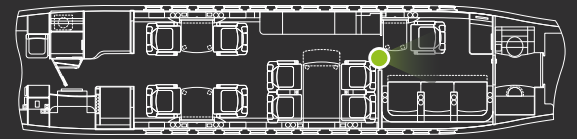

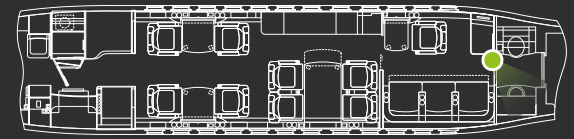

DASSAULT AVIATION**Yvon DESVIGNES**

Director, Pre-Owned Aircraft Sales

78, quai Marcel Dassault

92552 Saint-Cloud Cedex 300

France

Work Phone: + 33 1 47 11 61 24

Mobile: + 33 6 08 16 19 73

E-mail: yvon.desvignes@dassault-aviation.com

Nicolas MARTIN

Manager, Pre-Owned Aircraft Sales

78, quai Marcel Dassault

92552 Saint-Cloud Cedex 300

France

Work Phone: + 33 1 47 11 51 02

Mobile: + 33 6 26 79 50 50

Email: Nicolas.Martin@dassault-aviation.com

DASSAULT FALCON JET**Mark VERDESCO**

Director, Pre-Owned Aircraft Sales

200 Riser Road

Little Ferry, NJ 07643

USA

Work Phone: + 1 201 541 4556

Fax: + 1 201 541 4620

E-mail: Mark.Verdesco@dassaultfalconjet.com



