

Pre-Owned



Falcon 7X

S/N 143
2012





DASSAULT AVIATION

78, quai Marcel Dassault
Cedex 300
92552 Saint-Cloud Cedex
FRANCE

DASSAULT FALCON JET CORP.

200 Riser Road
Little Ferry, NJ 07643
USA

Falcon 7X

S/N 143

SPECIFICATIONS



Falcon 7X S/N 143 - 2012**ENGINE TYPE**

Pratt & Whitney Canada PW307A	on ESP "PLATINUM" with DTU (FAST 4G)
#1 Engine: PCE-CH0550	
#2 Engine: PCE-CH0549	
#3 Engine: PCE-CH0551	

APU TYPE

GTCP36-150 (FN)	SN- P256 TSN	On MSP "GOLD"
-----------------	--------------	---------------

MAINTENANCE

On CAMP. Next "2C" check due February 2028. Under FalconCare

EASy OPTIONS

EASy II 5th Cert, SBAS/LPV, ADS-B OUT, SVS, ADM, XM WEATHER, CPDLC ATN-B1, FANS 1/A+

AVIONICS**Honeywell Primus Epic System (EASy II, 5th Cert)**

FLIGHT DISPLAY SYSTEM (W/ FOUR 14 INCH LCD'S)		Honeywell EASY
COMMUNICATION (VHF DATA RADIO)	Triple	Honeywell TR 866B
COMMUNICATION (HF)	Dual	Honeywell KHF-1050
SELCAL VHF & HF		Honeywell
FLIGHT DECK AUDIO	Triple	Honeywell AV 900
EMERGENCY LOCATOR W/ NAV INTERFACE		Honeywell 406AF
SATCOM SYSTEM		Honeywell MCS-7120 - AERO H+ / SBB (WIFI)
VOR/ILS/MARKER/GPS	Dual	Honeywell NV875X
ADF SYSTEM	Dual	Honeywell DF-855
FLIGHT MANAGEMENT SYSTEMS (FMS)	Triple	Honeywell EASY
ELECTRONIC JEPPESEN CHARTS	Dual	Honeywell EASY
COLOR WEATHER RADAR		Honeywell PRIMUS 880
DME SYSTEM	Dual	Honeywell DM-855
ATC, TRANSPONDER	Dual	Honeywell XS- 857A W/ MODE S
RADAR ALTIMETER	Dual	Honeywell KRA-405B
TCAS II SYSTEM		ACSS TCAS 3000 (CHANGE 7.1)
HEAD-UP GUIDANCE SYSTEM		Rockwell COLLINS HGS-5860
ENHANCED FLIGHT VISION SYSTEM		Rockwell COLLINS EFVS-5860
MICRO INERTIAL REFERENCE UNIT	Triple	Honeywell LASEREF V
VOICE AND FLIGHT DATA COMBINED RECORDER	Dual	Honeywell AR-COMBI W/ CTS QAR
EGPWS W/ WINDSHEAR		Honeywell EASY

ADDITIONAL EQUIPMENT**Honeywell EASy:**

CMF, Flight deck video interface,
Uplink Weather Capability.

Entertainment System:

Rockwell Collins FCMS
Airshow 4000 w/ interactive capability
8.4" Touch Screen LCD Touch Screen Control
1ea. 21.3" LCD monitor & 1ea. 17" LCD monitor
1ea dual DVD player
1ea. PC Video (VGA) interface

Galley:

Extra large Galley (72") with one window
2ea. Hot Liquid Container
Enflight extra-wide high temp oven

Misc

Flight Deck Printer
Goodrich Ice Detectors
2ea Inverters (230 VAC 50 Hz 2000 VA) with 13 outlets
Telescopic tow bar
Direct and indirect LED lighting
Privacy curtains for divans
Specific Atlas storage cabinet in aft baggage compartment
2ea. 12-man life rafts

EXTERIOR

Overall white with two blue stripes on fuselage and fin.

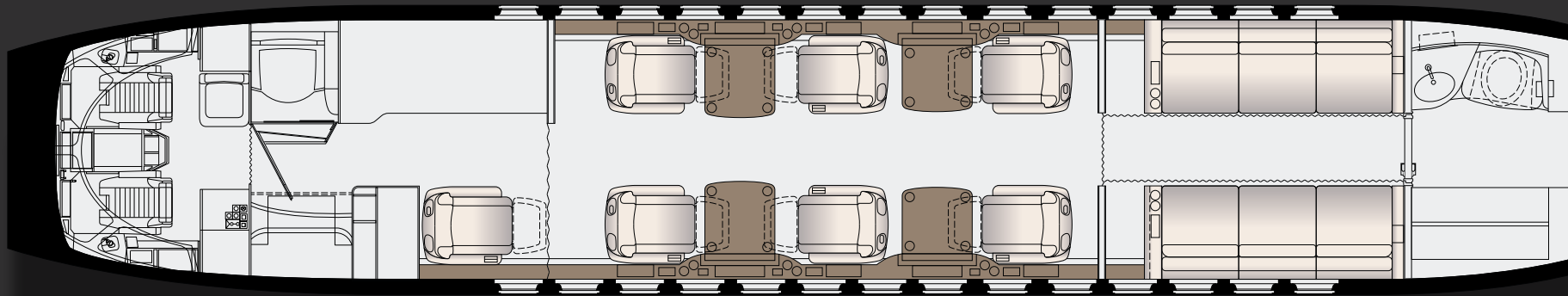

INTERIOR

Beige Harmony, Pommele Eucalyptus veneer and satin nickel metal plating in Cabin.

SEATING

13 Pax Floorplan (Exotic) w/ 3rd Crew seat,
Expanded Galley & Entryway 20" seat
Galley & Aft Cabin Divider curtains
Fwd & Aft Lavatories.

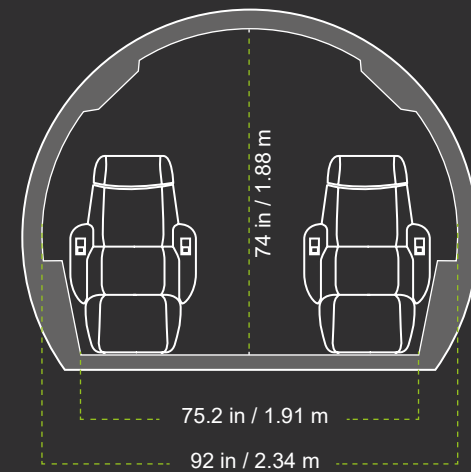

Falcon 7X

S/N 143

PHOTO GALLERY



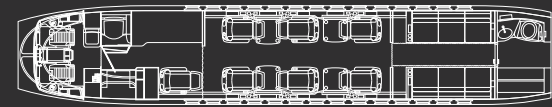

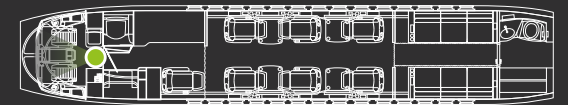

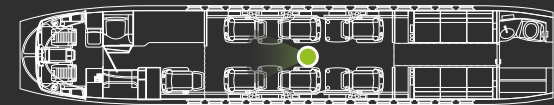

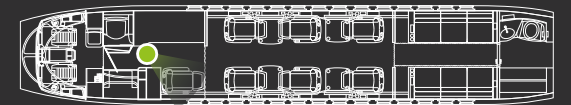

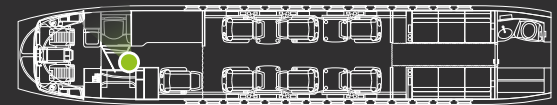

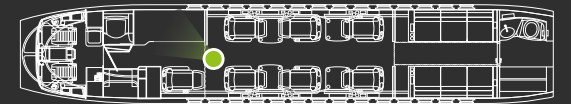



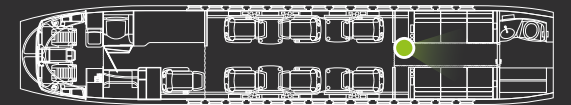

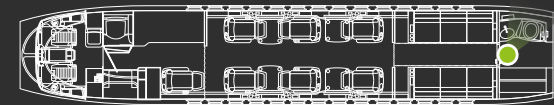

DASSAULT AVIATION**Yvon DESVIGNES**

Director, Pre-Owned Aircraft Sales

78, quai Marcel Dassault

92552 Saint-Cloud Cedex 300

France

Work Phone: + 33 1 47 11 61 24

Mobile: + 33 6 08 16 19 73

E-mail: yvon.desvignes@dassault-aviation.com

Nicolas MARTIN

Manager, Pre-Owned Aircraft Sales

78, quai Marcel Dassault

92552 Saint-Cloud Cedex 300

France

Work Phone: + 33 1 47 11 51 02

Mobile: + 33 6 26 79 50 50

Email: Nicolas.Martin@dassault-aviation.com

DASSAULT FALCON JET**Mark VERDESCO**

Director, Pre-Owned Aircraft Sales

200 Riser Road

Little Ferry, NJ 07643

USA

Work Phone: + 1 201 541 4556

Fax: + 1 201 541 4620

E-mail: Mark.Verdesco@dassaultfalconjet.com

